

MGD

Gas Detector and Controllers

Installation and Operation Manual
Instruction 1000-0083
Revision 0 – June 2013



WARRANTY POLICY

MURCO WARRANTS THIS INSTRUMENT, EXCLUDING SENSORS, TO BE FREE FROM DEFECTS IN MATERIALS AND WORKMANSHIP FOR A PERIOD OF TWO YEARS FROM THE DATE OF PURCHASE BY THE ORIGINAL OWNER. THE SENSORS HAVE A WARRANTY PERIOD OF ONE YEAR FROM THE DATE OF PURCHASE. IF THE PRODUCT SHOULD BECOME DEFECTIVE WITHIN THIS WARRANTY PERIOD, WE WILL REPAIR OR REPLACE IT AT OUR DISCRETION.

THE WARRANTY STATUS MAY BE AFFECTED IF THE INSTRUMENT HAS NOT BEEN USED AND MAINTAINED PER THE INSTRUCTIONS IN THIS MANUAL OR HAS BEEN ABUSED, DAMAGED, OR MODIFIED IN ANY WAY. THIS INSTRUMENT IS ONLY TO BE USED FOR PURPOSES STATED HEREIN. THE MANUFACTURER IS NOT LIABLE FOR AUXILIARY INTERFACED EQUIPMENT OR CONSEQUENTIAL DAMAGE.

DUE TO ONGOING RESEARCH, DEVELOPMENT, AND PRODUCT TESTING, THE MANUFACTURER RESERVES THE RIGHT TO CHANGE SPECIFICATIONS WITHOUT NOTICE. THE INFORMATION CONTAINED HEREIN IS BASED ON DATA CONSIDERED ACCURATE. HOWEVER, NO WARRANTY IS EXPRESSED OR IMPLIED REGARDING THE ACCURACY OF THIS DATA.

ALL GOODS MUST BE SHIPPED TO THE MANUFACTURER BY PREPAID FREIGHT. ALL RETURNED GOODS MUST BE PRE-AUTHORISED BY OBTAINING A RETURN MERCHANDISE AUTHORISATION (RMA) NUMBER. CONTACT THE MANUFACTURER FOR A NUMBER AND PROCEDURES REQUIRED FOR PRODUCT TRANSPORT.

SERVICE POLICY

MURCO MAINTAINS AN INSTRUMENT SERVICE FACILITY AT THE FACTORY. SOME MURCO DISTRIBUTORS / AGENTS MAY ALSO HAVE REPAIR FACILITIES, HOWEVER, MURCO ASSUMES NO LIABILITY FOR SERVICE PERFORMED BY ANYONE OTHER THAN MURCO PERSONNEL. REPAIRS ARE WARRANTED FOR 90 DAYS AFTER DATE OF SHIPMENT (SENSORS, PUMPS, FILTERS AND BATTERIES HAVE INDIVIDUAL WARRANTIES). SHOULD YOUR INSTRUMENT REQUIRE NON-WARRANTY REPAIR, YOU MAY CONTACT THE DISTRIBUTOR FROM WHOM IT WAS PURCHASED OR YOU MAY CONTACT MURCO DIRECTLY.

IF MURCO IS TO DO THE REPAIR WORK, SEND THE INSTRUMENT, PREPAID, TO MURCO AT THE FOLLOWING ADDRESS.

MURCO
114A GEORGE'S STREET LOWER
DUN LAOGHAIRE
CO DUBLIN IRELAND

ALWAYS INCLUDE YOUR RMA #, ADDRESS, TELEPHONE NUMBER, CONTACT NAME, SHIPPING/BILLING INFORMATION AND A DESCRIPTION OF THE DEFECT AS YOU PERCEIVE IT. YOU WILL BE CONTACTED WITH A COST ESTIMATE FOR EXPECTED REPAIRS PRIOR TO THE PERFORMANCE OF ANY SERVICE WORK. FOR LIABILITY

REASONS, MURCO HAS A POLICY OF PERFORMING ALL NEEDED REPAIRS TO RESTORE THE INSTRUMENT TO FULL OPERATING CONDITION.

PRIOR TO SHIPPING EQUIPMENT TO MURCO, CONTACT OUR OFFICE FOR AN RMA # (RETURNED MERCHANDISE AUTHORISATION). ALL RETURNED GOODS **MUST** BE ACCOMPANIED WITH AN RMA NUMBER.

PACK THE EQUIPMENT WELL (IN ITS ORIGINAL PACKING IF POSSIBLE), AS MURCO CANNOT BE HELD RESPONSIBLE FOR ANY DAMAGE INCURRED DURING SHIPPING TO OUR FACILITY.

NOTICES

COPYRIGHTS: THIS MANUAL IS SUBJECT TO COPYRIGHT PROTECTION; ALL RIGHTS ARE RESERVED UNDER INTERNATIONAL AND DOMESTIC COPYRIGHT LAWS. THIS MANUAL MAY NOT BE COPIED OR TRANSLATED, IN WHOLE OR IN PART, IN ANY MANNER OR FORMAT, WITHOUT THE WRITTEN PERMISSION OF MURCO.

ALL SOFTWARE USED AND/OR DISTRIBUTED BY MURCO IS SUBJECT TO COPYRIGHT PROTECTION. ALL RIGHTS ARE RESERVED. NO PARTY MAY USE OR COPY SUCH SOFTWARE IN ANY MANNER OR FORMAT, EXCEPT TO THE EXTENT THAT MURCO GRANTS THEM A LICENSE TO DO SO. IF THIS SOFTWARE IS BEING LOADED ONTO MORE THAN ONE COMPUTER, EXTRA SOFTWARE LICENSES MUST BE PURCHASED.

TECHNICIAN USE ONLY

THIS UNIT MUST BE INSTALLED BY A SUITABLY QUALIFIED TECHNICIAN WHO WILL INSTALL THIS UNIT IN ACCORDANCE WITH THESE INSTRUCTIONS AND THE STANDARDS IN THEIR PARTICULAR INDUSTRY/COUNTRY. OPERATORS OF THE UNIT SHOULD BE AWARE OF THE REGULATIONS AND STANDARDS IN THEIR INDUSTRY/COUNTRY FOR THE OPERATION OF THIS UNIT. THESE NOTES ARE ONLY INTENDED AS A GUIDE AND THE MANUFACTURER BEARS NO RESPONSIBILITY FOR THE INSTALLATION OR OPERATION OF THIS UNIT.

FAILURE TO INSTALL AND OPERATE THE UNIT IN ACCORDANCE WITH THESE INSTRUCTIONS AND WITH INDUSTRY GUIDELINES MAY CAUSE SERIOUS INJURY INCLUDING DEATH AND THE MANUFACTURER WILL NOT BE HELD RESPONSIBLE IN THIS REGARD.

Table of Contents

SECTION 1. OVERVIEW	5
1.1. GENERAL INFORMATION	5
1.2. TECHNICAL SPECIFICATIONS	10
SECTION 2. PLACING SENSORS	13
2.1. INSTALLATION WARNINGS	13
2.2. GENERAL GUIDELINES	13
2.3. MACHINERY ROOMS	15
2.4. REFRIGERATED SPACES	16
2.5. CHILLERS	16
2.6. AIR CONDITIONING (DIRECT SYSTEMS VRF/VRV)	17
SECTION 3. HOUSING DIMENSIONS	18
SECTION 4. WIRING INSTRUCTIONS	23
4.1. WIRING TO MGDs	23
4.2. EXTERNAL AUDIBLE ALARM AND DC OUTPUT	24
4.3. RELAYS	25
4.4. POWER CONNECTION	25
SECTION 5. OPERATION AND STABILISATION	31
SECTION 6. FUNCTIONAL TESTS AND CALIBRATION	33
6.1. INTRODUCTION	33
6.2. ELECTRICAL RESET OF ONE-ALARM SYSTEMS	35
6.3. ELECTRICAL RESET OF TWO-ALARM SYSTEMS	36
6.4. BUMP TESTING	37
6.5. CALIBRATION OVERVIEW	40
6.6. CALIBRATION OPTIONS	40
6.7. SENSOR BOARD EXCHANGE	40
6.8. ON-SITE GAS CALIBRATION (ONE-ALARM UNIT)	41
6.9. GAS CALIBRATION (TWO-ALARM UNITS)	43
SECTION 7. TROUBLESHOOTING	44
DECLARATION OF CONFORMITY	47

Section 1. Overview

1.1. General Information

The MGD is the ideal gas detection solution for installations requiring a quality and affordable stand-alone gas detector. It consists of 1 to 6 remote gas sensors connected to and powered by a controller. The controller provides visual, audible, and relay alarms on the detection of gases. The system is available with one or two levels of alarm.

The MGD can be used for:

- detecting refrigerant gases (including NH₃ and CO₂)
- speedy detection of combustible gases
- detection of toxic and VOC gases.

A range of gas detector and sensor enclosures are available for special applications.

The MGD Controller is required. With the MGD, it creates a stand-alone gas detection system and is used to remotely monitor up to six MGD devices. Models are available with 1, 2, 4, and 6 channels. Wiring diagrams are provided later in this manual.

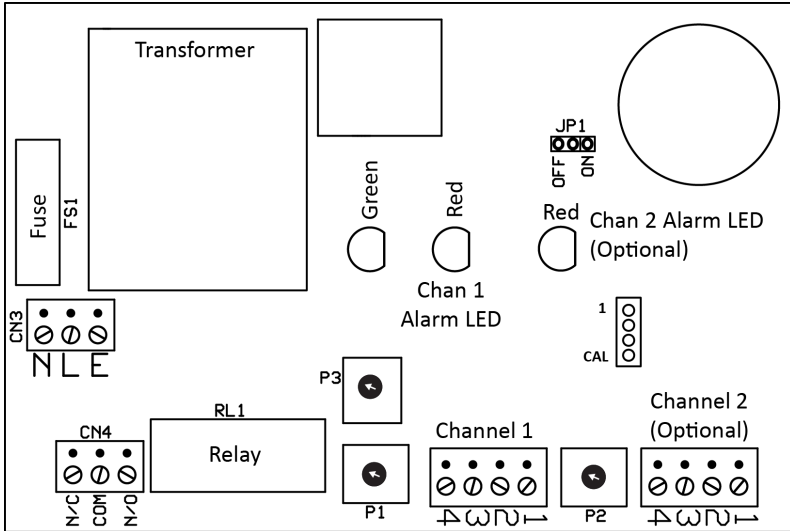

Figure 1. MGD 1- and 2-Channel Controller PCB (Single Level Alarm)

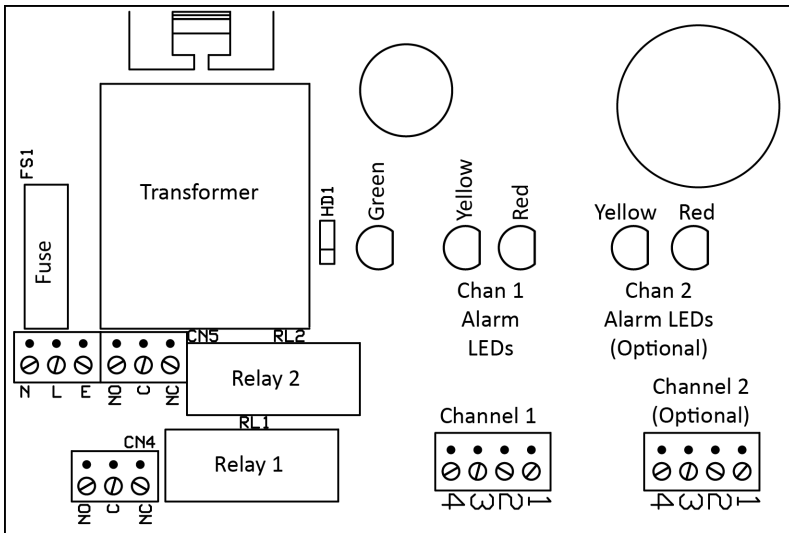

Figure 2. MGD 1- and 2-Channel Controller PCB (Dual Level Alarm)

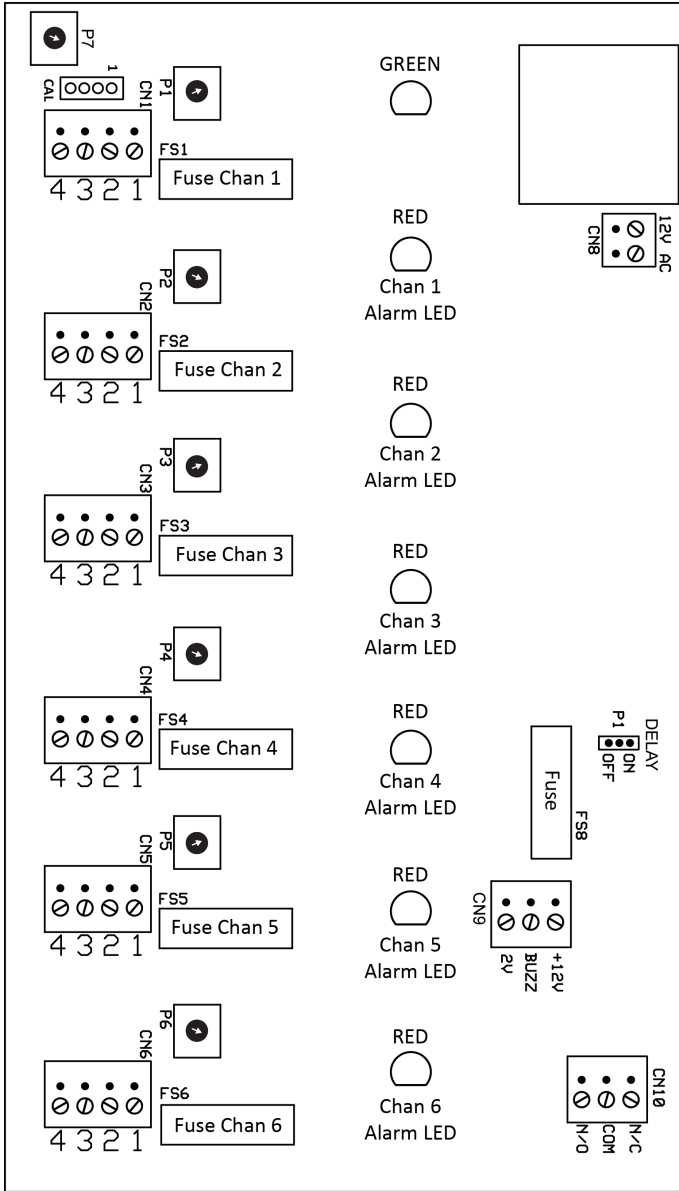

Figure 3. MGD 4- and 6-Channel Controller PCB (Single Level Alarm)

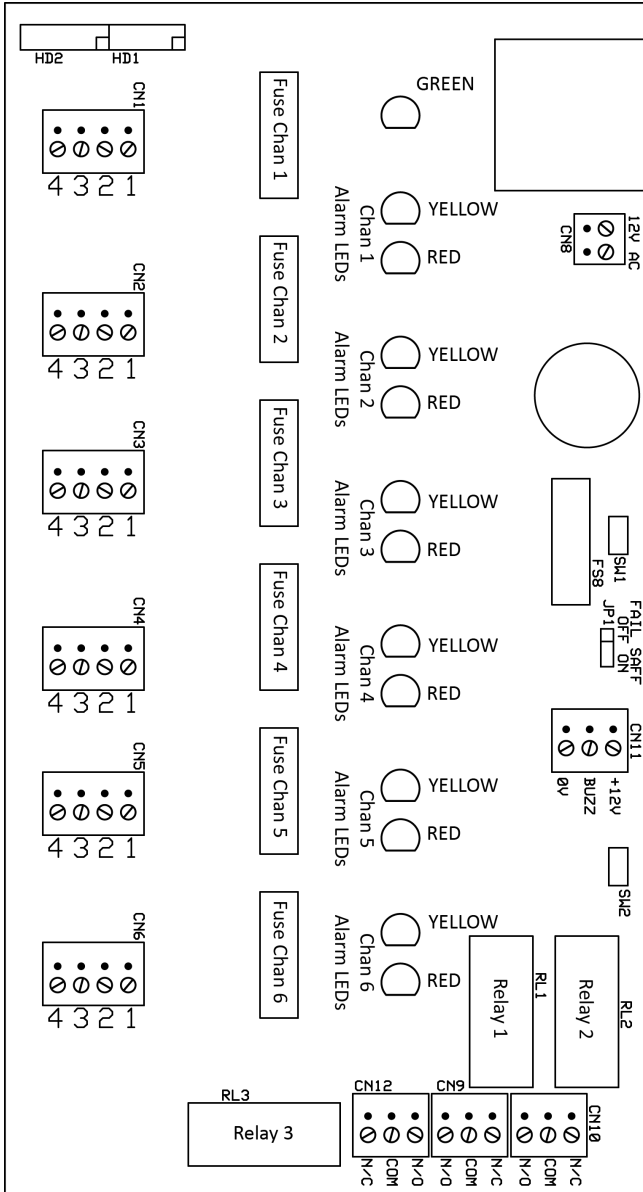

Figure 4. MGD 4- and 6-Channel Controller PCB (Dual Level Alarm)

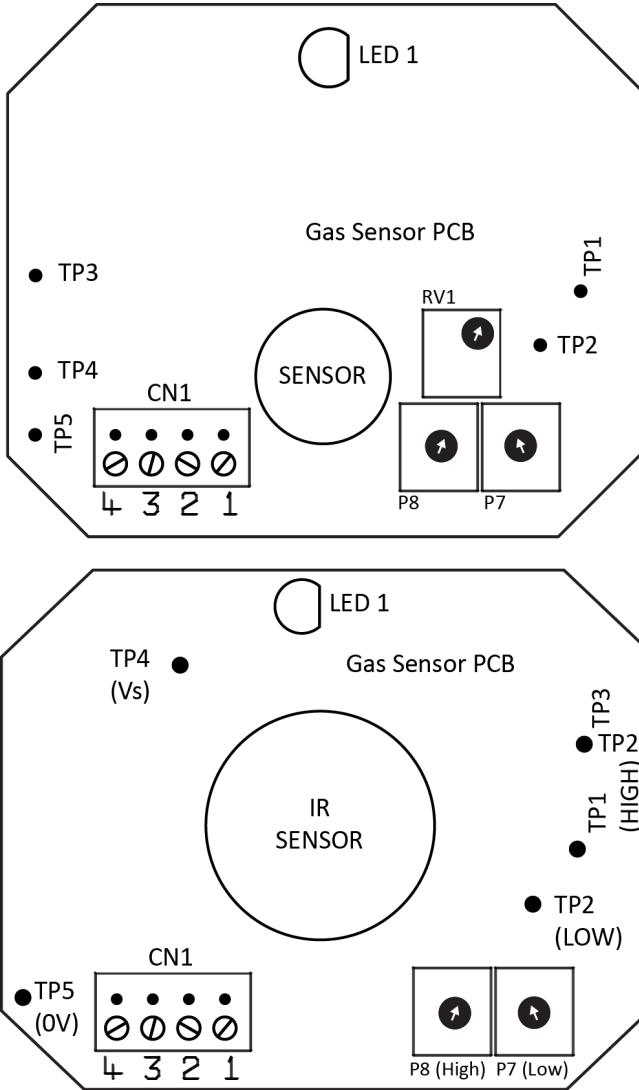

Figure 5. Example MGD Gas Sensor PCBs

1.2. Technical Specifications

Specification	Description			
Power Supply	120 VAC 60 Hz, 220 VAC 50 Hz, or 12 VDC (specified at time of order); Max power 20W			
	1- and 2-channel systems		4- and 6-channel systems	
Audible Alarm (Buzzer)	Internal, continuous	Internal, intermittent (low), continuous (high)	External, continuous	External, continuous
Alarm Silence	Jumper	Key Switch	Jumper	Key Switch
Alarm Levels	1 Level	2 Levels	1 Level	2 Levels
Alarm Reset	Automatic	Automatic (low alarm), manual (high alarm)	Automatic	Automatic (low alarm), manual (high alarm)
Alarm Delay	Selectable	Preset 25 sec (low) 30 sec (high)	Selectable	Preset 25 sec (low) 30 sec (high)
Visual Alarm LED(s)	Red	Yellow, Red	Red	Yellow, Red
Fault Indications	Red LED, relay		Red LED, relay	
Power Monitoring LED	Green		Green	
Alarm Relay(s)	10 A, 120V/230V		10 A, 120V/230V	
Communications Wiring	4-conductor cable, 200 ft (61 m) max w/ 22 AWG		4-conductor cable, 500 ft (152 m) max, 22 AWG	
Warm-up Delay	Minimum of 3 minutes			

Specification		Description	
	1- and 2-channel systems	4- and 6-channel systems	
Standard Enclosure Ratings	MGD: IP41 Controller: IP51	MGD: IP41 Controller: IP51	
Dimensions and Weight: Controller	8.4" x 4.1" x 3.15" 214 x 105 x 80 mm 2.9 lbs / 1.3 kg	10.3" x 10.4" x 303" 262 x 265 x 84 mm 5.7 lbs / 2.6 kg	
Dimensions and Weights	IP41	3.35" x 5.59" x 2.09" 86 x 142 x 53 mm	6.3 oz 180 g
	IP66	6.89" x 6.5" x 3.29" 175 x 165 x 82 mm	1 lb 6 oz 629 g
	IP66 w/ Splash Guard	6.89" x 8.9" x 3.29" 175 x 225 x 82 mm	1 lb 9 oz 700 g
	IP66 w/ Remote Sensor	6.89" x 6.1" x 3.29" 175 x 155 x 82 mm	1 lb 11 oz 790 g
	IP66 w/ Exd Remote Head	6.89" x 6.1" x 3.29" 175 x 155 x 82 mm	2 lb 10 oz 1185 g
	IP66 w/ PRV Sensor Head	6.89" x 6.1" x 3.29" 175 x 155 x 82 mm	2 lb 0.3 oz 916 g
	IP66 Airflow/ Duct (See Table)	6.89" x 4.9" x 3.29" 175 x 125 x 82 mm	1 lb 4 oz 578 g
	Exd (ATEX only)	5.12" x 6.3" x 3.54" 130 x 160 x 90 mm	9 lb 4 oz 4200 g



NOTE: The hazardous area **Exd Gas Monitor** products are designed with individually certified Exd main housing enclosures and certified Exd remote or attached sensor enclosures. The main housing enclosure and its PCB assembly are also Exd certified, but the final **Exd Gas Monitor** assemblies (main enclosure and/or sensor assembly) are not currently Exd certified, but are pending additional testing.

Supported CFM/Duct Sizes for the Duct Mount Housing

Units		Duct Size			
Inches	12 x 12	12 x 24	18 x 18	24 x 24	24 round
Feet	1 x 1	1 x 2	1.5 x 1.5	2 x 2	Pi x 1 x 1
Area (ft ²)	1	2	2.25	4	3.14
CFM	Ft/min (Based on CFM and Duct Size)				
2800	2800	n/a	n/a	n/a	n/a
3000	3000	n/a	n/a	n/a	n/a
3400	3400	n/a	n/a	n/a	n/a
3800	3800	n/a	n/a	n/a	n/a
4000	4000	n/a	n/a	n/a	n/a
4400	4400	n/a	n/a	n/a	n/a
4800	4800	n/a	n/a	n/a	n/a
5000	5000	2500	n/a	n/a	n/a
5400	5400	2700	n/a	n/a	n/a
5800	5800	2900	2578	n/a	n/a
6000	6000	3000	2667	n/a	n/a
6400	6400	3200	2844	n/a	n/a
6800	6800	3400	3022	n/a	n/a
7000	7000	3500	3111	n/a	n/a
7400	7400	3700	3289	n/a	n/a
7800	7800	3900	3467	n/a	n/a
8000	8000	4000	3556	n/a	2548
8400	8400	4200	3733	n/a	2675
8800	8800	4400	3911	n/a	2803
9000	9000	4500	4000	n/a	2866
9400	9400	4700	4178	n/a	2994
9800	9800	4900	4356	n/a	3121
10000	10000	5000	4444	2500	3185

Section 2. Placing Sensors

2.1. Installation Warnings



NOTE: This instrument can be equipped with a semiconductor sensor for the detection of refrigerant, combustible and VOC gases. Semiconductor sensors are not gas specific and respond to a variety of other gases including propane exhaust, cleaners, and solvents. Changes in temperature and humidity may also affect the sensor's performance.



WARNING: Explosion hazard! Do not mount the MGD in an area that may contain flammable liquids, vapors, or aerosols. Operation of any electrical equipment in such an environment constitutes a safety hazard.



CAUTION: The MGD contains sensitive electronic components that can be easily damaged. Do not touch nor disturb any of these components.



NOTE: The mounting location of the monitor should allow it to be easily accessible for visual monitoring and servicing.



NOTE: The monitor must be connected by a marked, suitably located and easily reached switch or circuit-breaker as means of disconnection.



NOTE: Connect monitor power and signaling terminals using wiring that complies with local electrical codes or regulations for the intended application.

2.2. General Guidelines



NOTE: The MGD should be installed plumb and level and securely fastened to a rigid mounting surface.

The MGD controller and its sensor(s) should be positioned carefully to avoid mechanical damage (from moving machinery, doors, etc.) and thermal extremes (close to heaters). Units should not be placed unprotected in direct

strong drafts/airflows and areas where water or moisture is present unless an appropriate enclosure is used.

Avoid routing sensor cabling outside of premises, or between buildings via overhead cables. Also, sensor wiring should be kept to a minimum of 20 in (500mm) from the main power supply and telephone cables.

When connecting the main power supply and/or sensor cables ensure a second mechanical fixing is used. Use a cable tie inside the enclosure within 1 in (25mm) of the cable termination.

When power to the unit is switched on, there is a 3-minute delay before the system activates. This allows the sensors to warm up to the correct temperature for gas detection. On a two-alarm unit, the green light on the alarm panel comes on after the delay, indicating that the system is ready. On a one-alarm system the green light comes on immediately. When a unit has been off or stored for a long time the stabilising period may be longer than 3 minutes. After the 3 minutes has expired, alarms may activate. You may deactivate the siren until stabilisation is complete. (Use the key switch on two-alarm units. Remove jumper JP1 in the case of a one-alarm unit).

Mount the controller using the mounting holes in the base such that the sensor cable terminal blocks are at the bottom of the unit in a convenient position.

Sensors must be located within the appropriate wire lengths from the controller.

In all cases the sensor supplied is designed for maximum sensitivity to a particular gas. However, in certain circumstances false alarms may be caused by the occasional presence of sufficiently high concentrations of other gaseous impurities. Examples of situations where such abnormalities may arise include the following:

- Plant room maintenance activity involving solvent or paint fumes or refrigerant leaks.
- Accidental gas migration in fruit ripening/storage facilities (bananas - ethylene, apples - carbon dioxide).
- Heavy localised exhaust fumes (carbon monoxide, dioxide, propane) from engine-driven forklifts in confined spaces or close to sensors.

A response delay is built in to the system to minimise the possibilities of false alarms (for two-alarm units only) or it may be selected for one-alarm units.

2.3. Machinery Rooms

There is no absolute rule in determining the number of sensors and their locations. However, a number of simple guidelines will help to make a decision. Sensors monitor a point as opposed to an area. If the gas leak does not reach the sensor then no alarm will be triggered. Therefore, it is extremely important to carefully select the sensor location. Also consider ease of access for maintenance.

The size and nature of the site will help to decide which method is the most appropriate to use. Locations requiring the most protection in a machinery or plant room would be around compressors, pressurised storage vessels, refrigerant cylinders or storage rooms or pipelines. The most common leak sources are valves, gauges, flanges, joints (brazed or mechanical), filling or draining connections, etc.

- When **mechanical or natural ventilation** is present, mount a sensor in the airflow.
- In machinery rooms where there is **no discernible or strong airflow** then options are:

Point Detection, where sensors are located as near as possible to the most likely sources of leakage, such as the compressor, expansion valves, mechanical joints or cable duct trenches.

Perimeter Detection, where sensors completely surround the area or equipment.

- For **heavier-than-air gases** such as halocarbon and hydrocarbon refrigerants such as R404A, propane, and butane sensors should be located near ground level.
- For **lighter-than-air gas** (e.g., ammonia), the sensor needs to be located above the equipment to be monitored on a bracket or high on a wall within 12 in (300 mm) of (or on) the ceiling – provided there is no possibility of a thermal layer trapped under the ceiling preventing gas from reaching the sensor.



NOTE: At very low temperatures (e.g., refrigerated cold store), ammonia gas becomes heavier than air.

- With similar density or miscible gases, such as CO or CO₂, sensors should be mounted about head high (about 5 feet [1.5 m]).
- Sensors should be positioned just far enough back from any high-

pressure parts to allow gas clouds to form and be detected. Otherwise, a gas leak might pass by in a high-speed jet and not be detected by the sensor.

- Make sure that pits, stairwells and trenches are monitored since they may fill with stagnant pockets of gas.
- If a pressure relief vent (PRV) pipe is fitted to the system, it may be a requirement to mount a sensor to monitor this vent pipe. It could be positioned about 6.5 ft (2 m) above the PRV to allow gas clouds to form.
- For racks or chillers pre-fitted with refrigerant sensors, these should be mounted so as to monitor the compressors. If extract ducts are fitted the airflow in the duct may be monitored.

2.4. Refrigerated Spaces

In refrigerated spaces, sensors should be located in the return airflow to the evaporators on a sidewall (below head-high is preferred), or on the ceiling, not directly in front of an evaporator. In large rooms with multiple evaporators, sensors should be mounted on the central line between 2 adjacent evaporators, as turbulence will result in airflows mixing.

2.5. Chillers

In the case of small water- or air-cooled enclosed chiller units mount the sensor so as to monitor airflow to the extract fans. With larger models also place a sensor inside the enclosure under or adjacent to the compressors.

In the case of outdoor units:

- For enclosed air-cooled chillers or the outdoor unit for variable refrigerant volume and variable refrigerant flow (VRV/VRF) systems, mount the sensor so as to monitor airflow to the extractor/exhaust fan. With large units also place a sensor inside the enclosure under or adjacent to the compressors.

In the case of non-enclosed outdoor units:

- If there is an enclosed machinery section, locate a sensor there.
- In the case of units with enclosed compressors, mount sensors in the enclosures.
- Where you have protective or acoustic panels mount the sensor low and under the compressors where it is protected by the panels.

- With air-cooled chillers or air-cooled condensers with non-enclosed condenser sections it is difficult to effectively monitor leaks in the coil sections. With some designs it will be possible using an airflow sensor to monitor airflow to the start-up fans in the front or rear sections.
- If there is a possibility of refrigerant leaks into a duct or air-handling unit install a sensor to monitor the airflow.

Weatherproof sensors should be used for unprotected outdoor applications.

2.6. Air Conditioning (Direct Systems VRF/VRV)

For compliance with EN378, at least one detector shall be installed in each occupied space being considered and the location of detectors shall be chosen in relation to the refrigerant and they shall be located where the refrigerant from the leak will collect. In this case refrigerants are heavier than air and detectors should have their sensors mounted low, e.g., at less than bed height in the case of an hotel or other similar Category Class A spaces. Ceilings or other voids if not sealed are part of the occupied space.



CAUTION: Monitoring ceiling voids in a hotel room would not strictly comply with EN378.

Do Mount In-Room Sensors...	Don't Mount Sensors...
...at less than the normal heights of the occupants. E.g., in a hotel room this is less than bed height (between 8 and 20 in [200 and 500 mm] off the floor).	...under mirrors.
...away from drafts and heat sources like radiators, etc.	...at vanity units.
... to avoid sources of steam.	...in or near bathrooms.



IMPORTANT: Carefully consider ramifications of using too few sensors. A few extra sensors could make a significant difference if a gas leak occurs.

Section 3. Housing Dimensions

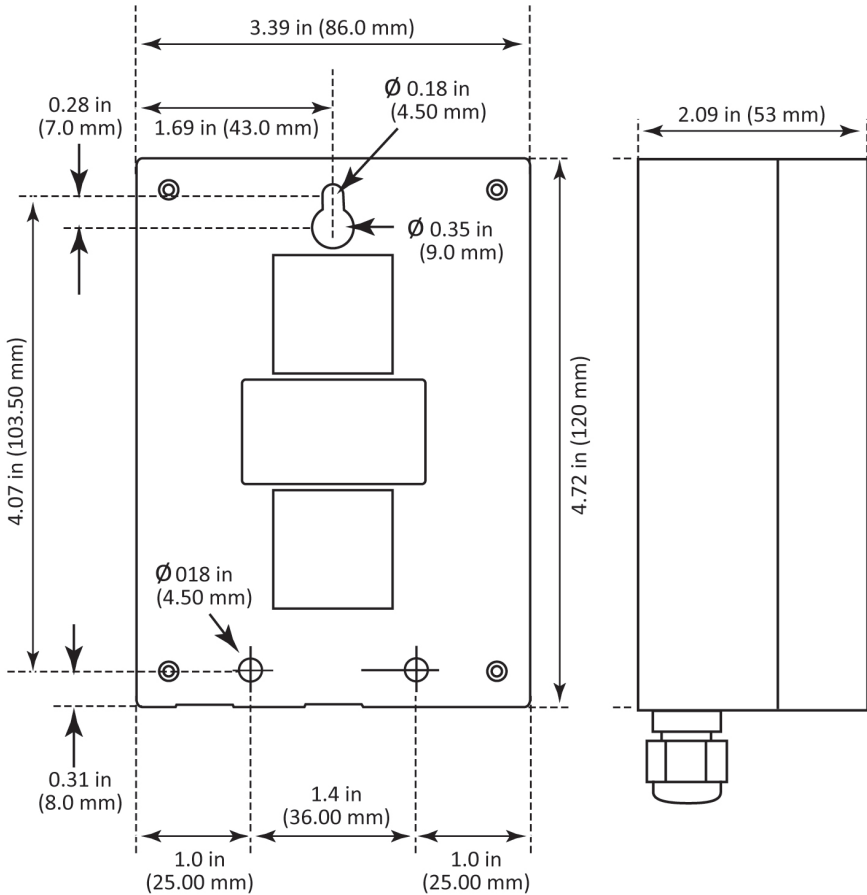

Figure 6. MGD Standard Housing

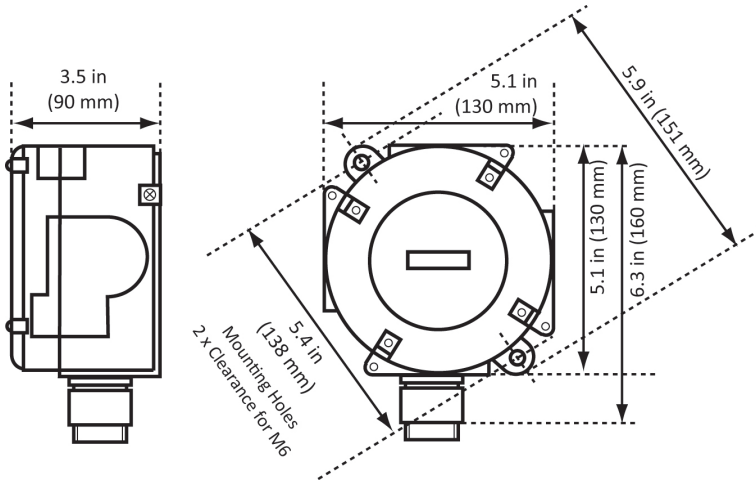

Figure 7. MGD Exd Housing

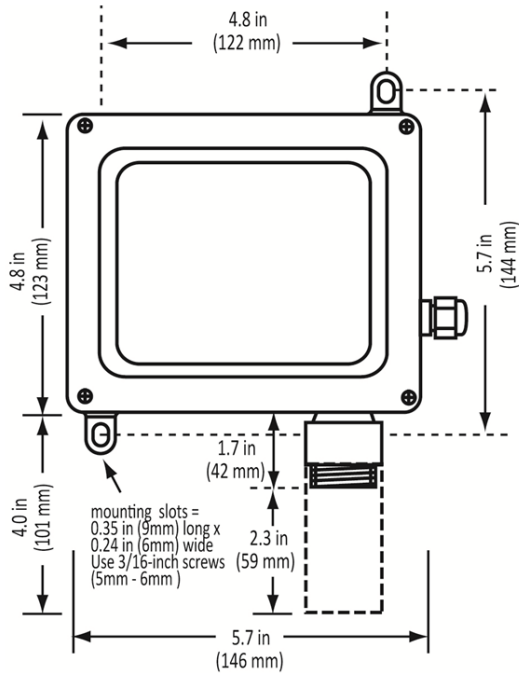

Figure 8. MGD IP66 Housing (with Splash Guard)

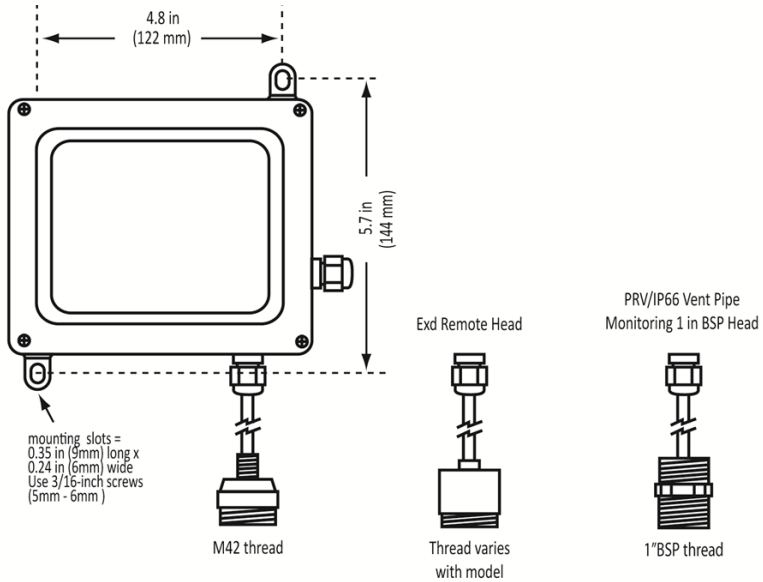

Figure 9. MGD IP66 Housing with Remote Sensor

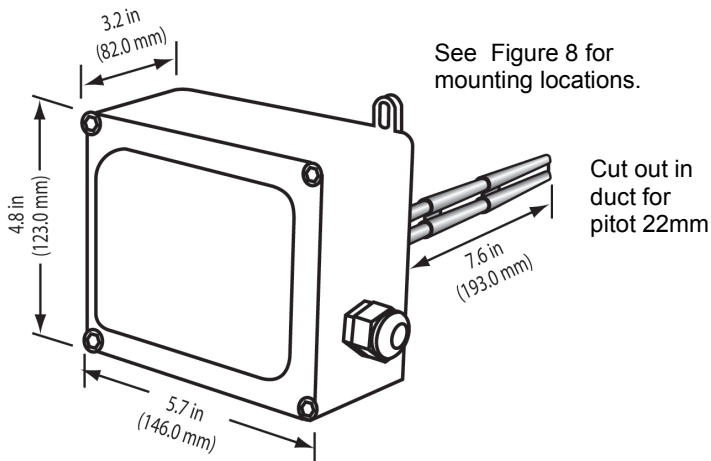

Figure 10. MGS-100 IP66 Housing with Airflow Duct Mount

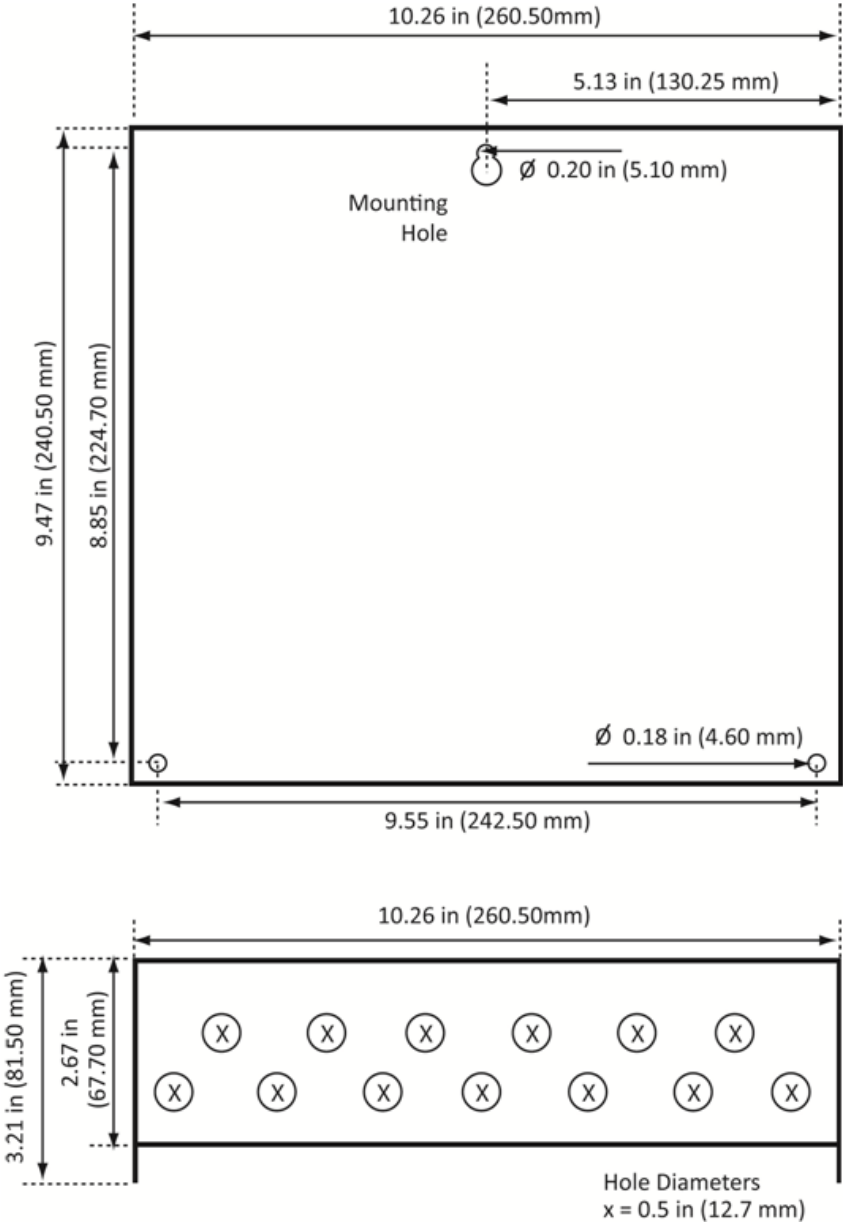

Figure 11. 4- & 6-Sensor Controller Housing

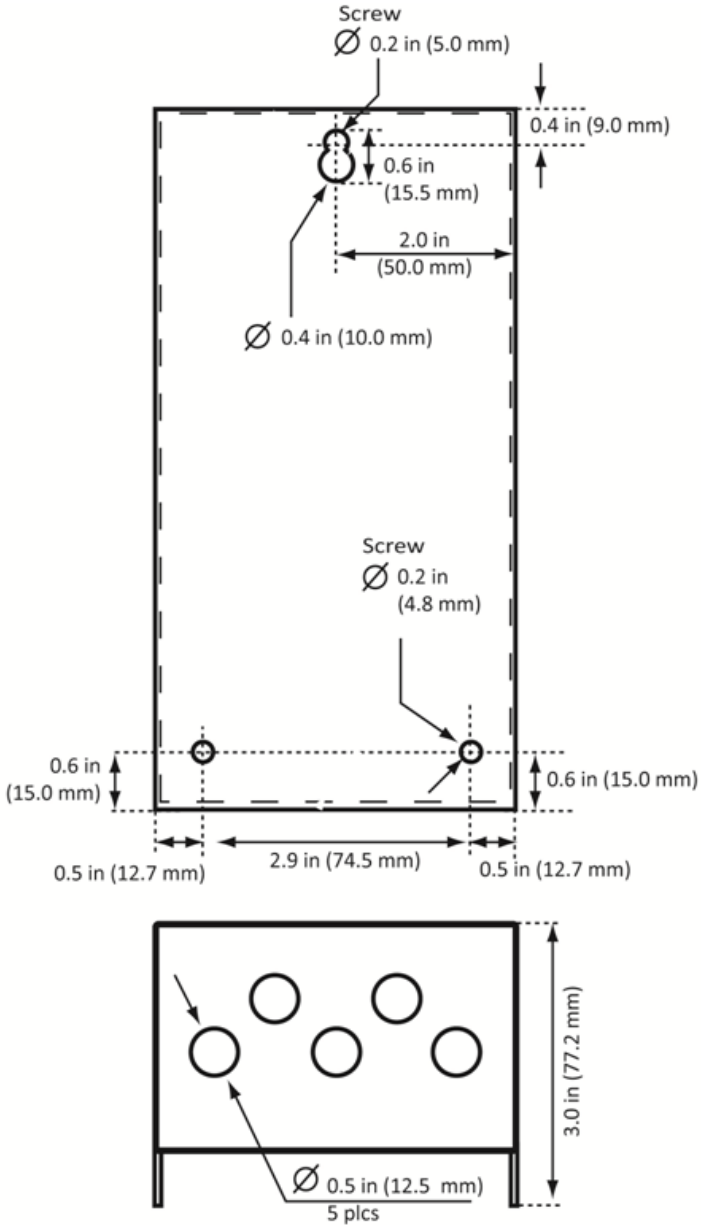

Figure 12. 1- to 2-Sensor Controller Housing

Section 4. Wiring Instructions

4.1. Wiring to MGDs

Step	Wiring to MGDs
1	Connect a 4-conductor cable (18 AWG recommended) to a terminal block on the MGD controller (CN1, CN2, etc).
2	Route the cable to an MGD.
3	For standard (IP41) MGD housings, remove the lid by: <ul style="list-style-type: none"> • turning the cable clamp ½ turn counter clockwise to loosen the internal nut • depressing the clip on top of the enclosure to open.
4	Mount the MGD. See Section 3 for dimensions.
5	Connect the other end of the cable to the MGD using terminal block CN1 positions 1,2,3 & 4. (Installation should be such that pin 1 of the MGD controller is connected to pin 1 of the MGD).
6	Close the housing.
7	Repeat above sequence for any/all remaining MGDs.



NOTE: Install a 2200 Ohm resistor between input pins 2 and 3 on any unused channels. If unused channels do NOT have a resistor installed a fault will occur.

Maximum Wiring Lengths between MGD and Controller

System	1-2 Channel Units	4-6 Channel Units
120 Volt	Length: 200 feet max AWG: 22 gauge Type: Stranded 4-wire cable Ohms: Max 3.52Ω/wire	Length: 500 feet max AWG: 22 gauge Type: Stranded 4-wire cable Ohms: Max 8.8Ω/wire
230 Volt	Length: 125 feet max AWG: 22 gauge Type: Stranded 4-wire cable Ohms: Max 3.52Ω/wire	Length: 325 feet max AWG: 22 gauge Type: Stranded 4-wire cable Ohms: Max 8.8Ω/wire



IMPORTANT: Ensure that connections 1 to 4 on the sensor connect to their corresponding numbers on the terminal block in the main control unit, otherwise it could cause damage to the MGD.



NOTE: You may use different cables and longer distances provided the corresponding resistance shown above is not exceeded.

4.2. External Audible Alarm and DC Output



NOTE: This section applies to the external audible alarm and the 12 VDC output (4-6 channel systems only).

Step	Wiring the External Audible Alarm and DC Output
1	To install the audible alarm, connect positive lead to CN9 terminal (for one-alarm models) or CN11 terminal (for two-alarm models) marked +12V.
2	Connect the negative to the center terminal marked 'BUZZ'.
3	<p>The 12 VDC/100 mA output is obtained via CN9/CN11 terminals '+12V' and '0V'. This output may be wired via the relays to obtain a switching 12 VDC output to drive an external relay or solenoid.</p> <hr/> <p> NOTE: If both the buzzer and 12V DC output are connected correctly, they should not exceed 250 mA in total.</p> <hr/>
4	Connect terminal '+12V' on CN9/CN11 to the 'COM' terminal of the relay and the device to be switched to either the N/O or N/C terminal (depending on whether a 12V output is required during an alarm condition or while the system is on standby).
5	The return from the device is connected to Zero on CN9/CN11.

4.3. Relays

Connect leads to terminal block for Common (COM) and N/O and/or N/C connections as required. Note that relays are rated as 10A @ 120/230 VAC.

Relay Wiring

Type	Two-Alarm Units	One-Alarm Units
1-2 Channel Units	CN5: Low-Level Alarm CN4: High-Level Alarm	CN4
4-6 Channel Units	CN10: Low-Level Alarm CN9: High-Level Alarm CN12: Fault Relay	CN10



NOTE: N/O (normally open) and N/C (normally closed) refer to contact status in standby mode. On a two-alarm system, a high-level alarm condition on any sensor will override a low-level alarm condition on another sensor.



NOTE: On 4- to 6-channel, two-alarm units, the high-level relay may be set for normal or Fail-Safe operation by setting jumper JP1 on the control unit's printed circuit board.

4.4. Power Connection

Use 3-wire, 20 AWG wire for 230V systems or 3-wire, 18 AWG wire for 120V systems. Connect the main power supply to terminal block CN3 (on 1 & 2 channel systems), or fused terminal block mounted on base of control unit (4 - 6 channel systems). Ensure that ground connections to the lid and base of the enclosure are maintained.



NOTE: Connection to the main power supply must be made via an approved, readily-accessible, switched and fused plug and socket (or as per local wiring regulations) which should be within 10 feet (3 meters) of the control unit.



NOTE: The main power supply cable should be of an approved type based on local regulations.



NOTE: The blanking plugs for cable entries should only be removed if being replaced by conduit fittings.



NOTE: If replacement of the main power fuse is required, use only the appropriate type from the table below.

Replacement Fuses (0.79 in [20mm])

Control Unit		Main Supply Fuse	Sensor Connection Fuse	Audible Alarm/Aux Fuse
230-Volt Systems	1-2 Chan Units	T50mA 230V Fuse	N/A	N/A
	4-6 Chan Units	T160mA 230V Fuse	T250mA 230V Fuse	T315mA 230V Fuse
120-Volt Systems	1-2 Chan Units	T100mA 120V Fuse	N/A	N/A
	4-6 Chan Units	T315mA 230V Fuse	T250mA 120V Fuse	T315mA 230V Fuse

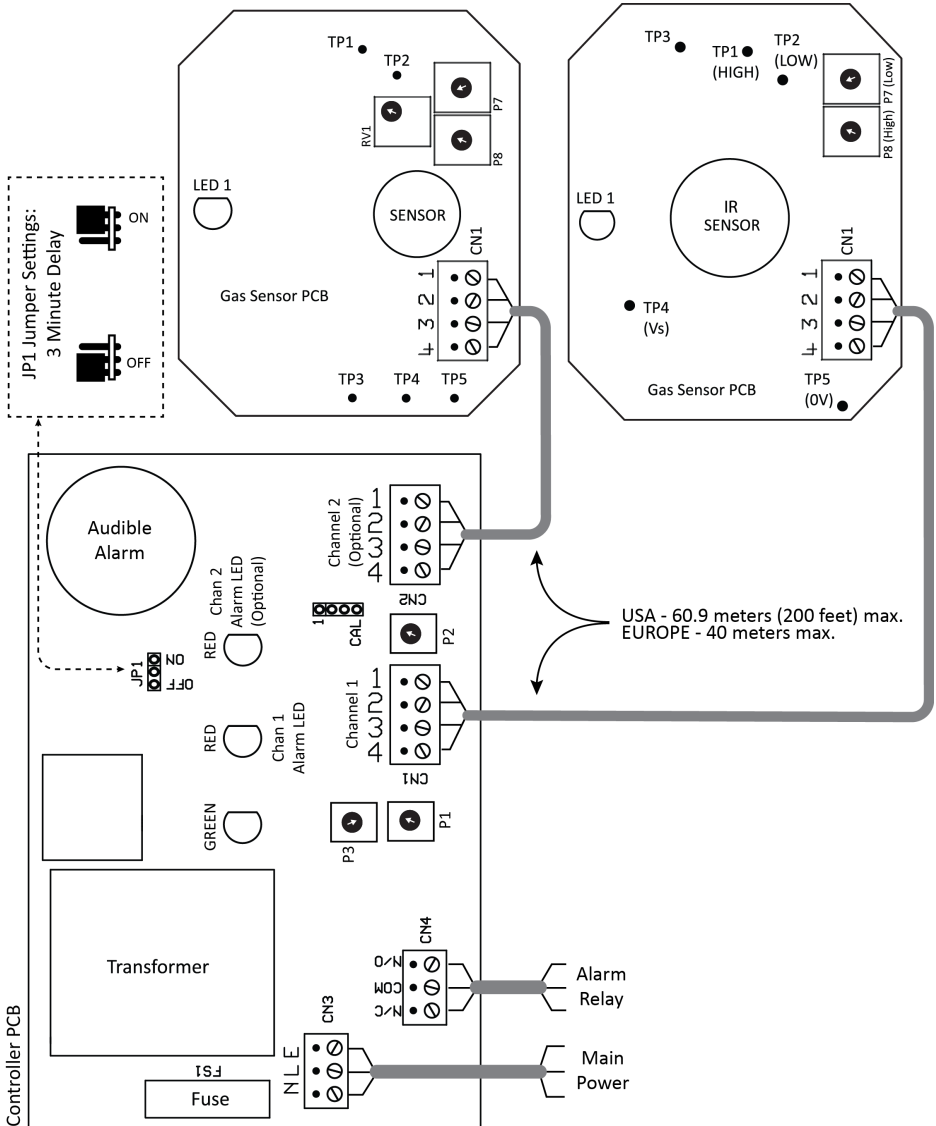

Figure 13. 1- & 2-Sensor, One-Alarm Installation Diagram

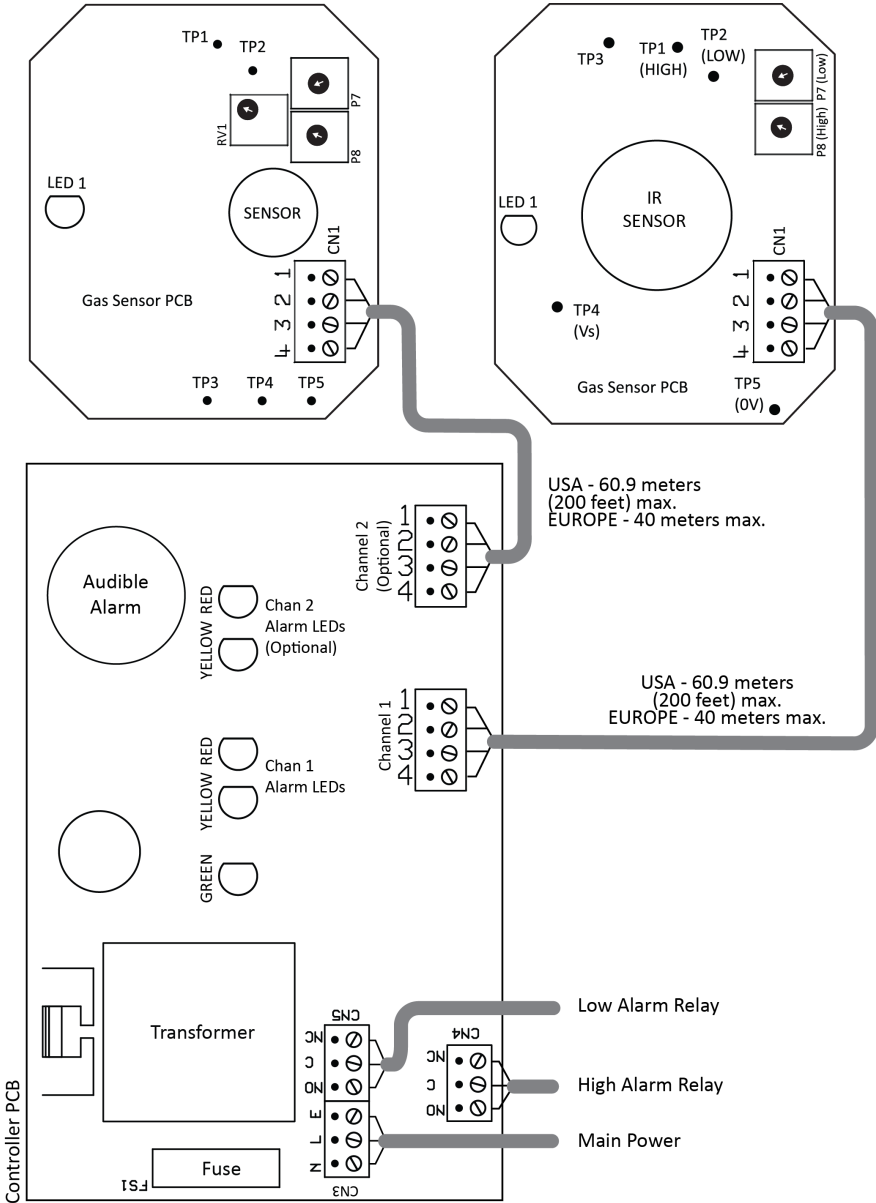

Figure 14. 1- & 2-Sensor, Two-Alarm Installation Diagram

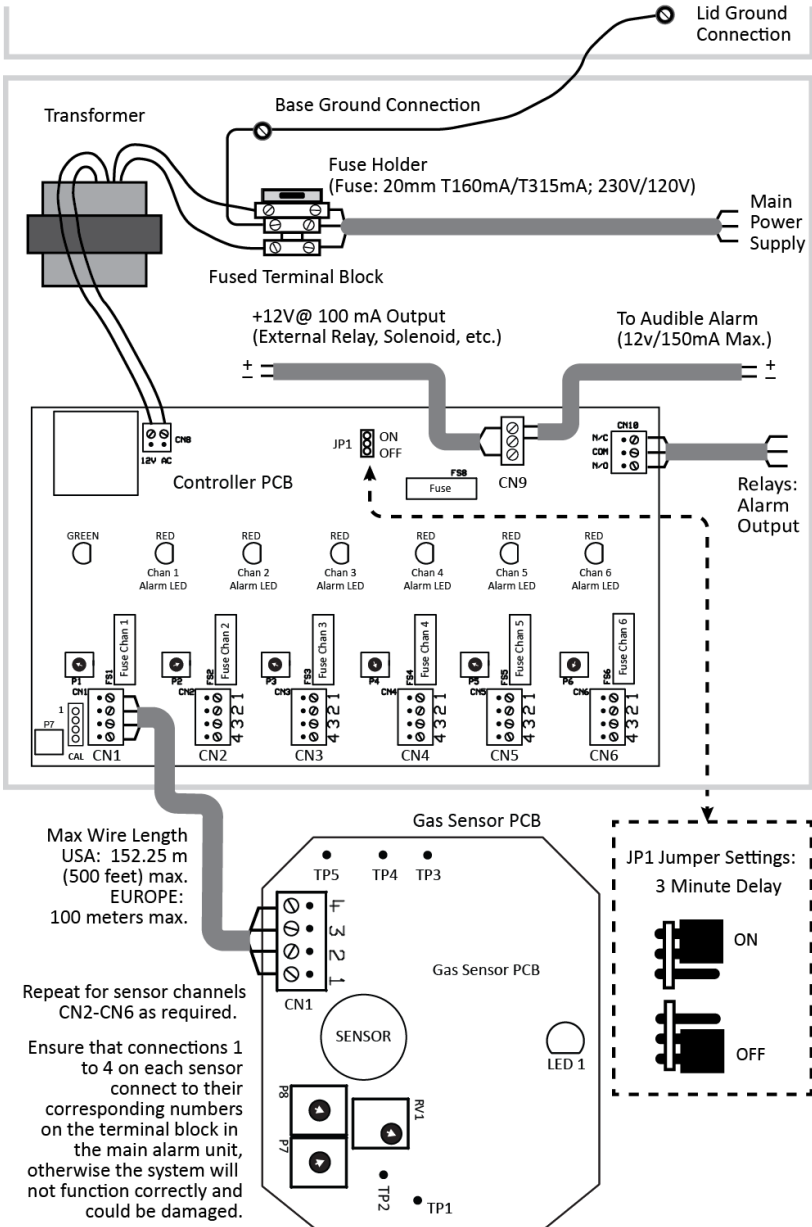

Figure 15. 4- & 6-Sensor, One-Alarm Installation

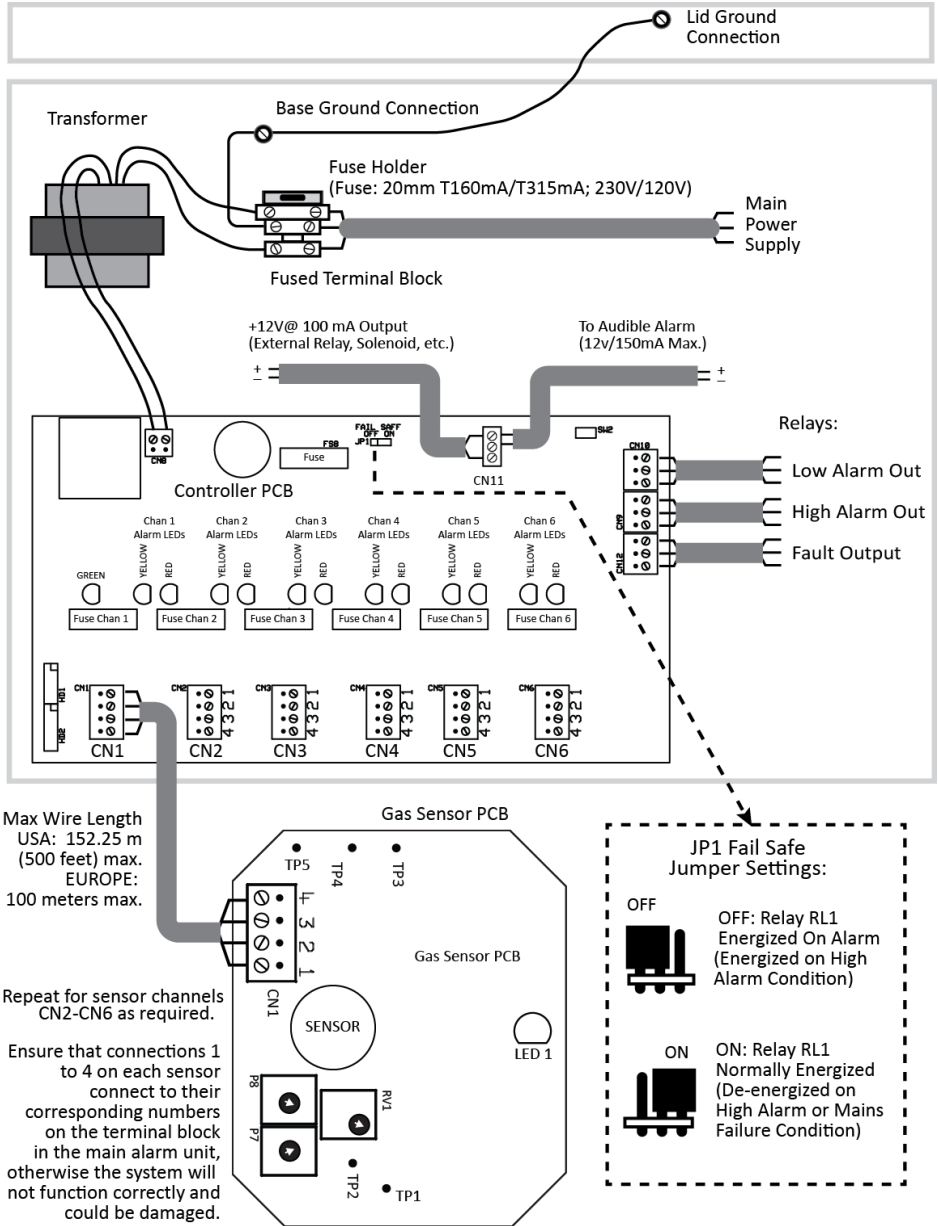

Figure 16. 4- & 6-Sensor, Two-Alarm Installation

Section 5. Operation and Stabilisation

When power to the unit is switched on, there is a 3-minute delay before the system activates. This allows the sensors to warm up to the correct temperature for gas detection.

- On a two-alarm unit the green light on the alarm panel comes on after the delay, indicating that the system is ready.
- On a one-alarm unit the green light comes on immediately.



NOTE: The 3-minute delay is set by JP1 in single alarm units only. For 2 alarm units, the delay is always enabled.

When a unit has been off or stored for a long time the stabilising period may be longer than 3 minutes. After the 3 minutes has expired, alarms may activate. You may deactivate the siren until stabilisation is complete. (Use the key switch on two-alarm units. Remove link on jumper JP1 in the case of one-alarm units).

After the MGD has been installed in accordance with the installation instructions, the MGD system is ready to monitor the chosen air space and detect gas leaks.

Each of the remote sensors has a green light to indicate that power is present.

To minimise false alarms, the system has a built in delay enforced between the arrival time of gas at the sensor unit, and the time when the alarm occurs. For one-alarm units, this delay is approximately 3 minutes. For two-alarm units, this delay is 20-25 seconds before a low-level alarm, and 25-30 seconds before a high-level alarm. This delay can be deactivated in a one-alarm unit by moving the link at position JP1 to the off position.

MGD Installation and Operation Manual

State	Description
Idle	Only the green light on the panel is on. No gas is present.
Power Interrupted	If the green light is off, power to the unit has been interrupted. Refer to Section 7.
Alarm Conditions	<p>One-alarm Units: One or more red lights on the panel turn on. The siren and the relays operate. This indicates that gas at one or more sensors is at a level higher than the alarm point.</p>
	<p>Two-alarm Units: <u>Low Alarm:</u> One or more yellow lights on the panel turn on. The audible alarm operates intermittently, and the low alarm relay operates: this indicates presence of a low level of gas on one or more sensors. <u>High Alarm:</u> One or more red lights on the panel turn on. The audible alarm operates continuously, and the high alarm relay operates: this indicates presence of a high level of gas on one or more of the sensors.</p>
Resetting Alarms	<p>On one-alarm units all of which have automatic reset no user intervention is required. The unit will reset shortly after the gas dissipates (all one-alarm systems reset automatically).</p> <p>On two-alarm units, low-level alarm conditions will reset automatically when the gas dissipates. High-level alarm conditions require a manual reset (by pressing the reset button). Please note that a high alarm condition can only be reset 30-60 seconds after the gas clears from around the sensors.</p>
Audible Alarm	For the purpose of system maintenance, the audible alarm may be disabled temporarily on two-alarm units by using the key-switch. On one-alarm units this is achieved by setting a jumper on the control unit printed circuit board. The location of this is position JP1. Remove the link to disable the alarm.
Fault	This indicates a wiring or sensor problem. If these are in order, the calibration pot may have been adjusted and may need to be reset. Check with the factory for instructions.

Section 6. Functional Tests and Calibration

6.1. Introduction

To comply with the requirements of EN378 and the European F-GAS regulation, sensors must be tested annually. However, local regulations may specify the nature and frequency of this test.



CAUTION: Check local regulations on calibration or testing requirements.



CAUTION: The MGD contains sensitive electronic components that can be easily damaged. Do not touch nor disturb any of these components.



NOTE: The MGD is calibrated at the factory. After installation, a zero adjustment may be required due to differences in environmental conditions.



IMPORTANT: If the MGD is exposed to a large leak it should be tested to ensure correct functionality by electrically resetting the zero setting and carrying out a bump test. See procedures below.



IMPORTANT: Before testing the sensors on-site, the MGD must have been powered up and allowed to stabilise for at least 24 hours. See Section 5.



IMPORTANT: Failure to test or calibrate the unit in accordance with applicable instructions and with industry guidelines may result in serious injury or death. The manufacturer is not liable for any loss, injury, or damage arising from improper testing, incorrect calibration, or inappropriate use of the unit.



IMPORTANT: Murco recommends annual checks and gas calibration. Murco also recommends sensor replacement every 3 years or as required. Calibration frequency may be extended based on application, but should never exceed 2 years.

IMPORTANT: The testing and/or calibration of the unit must be carried out by a suitably qualified technician, and must be done in accordance with this manual and in compliance with locally applicable guidelines and regulations.



Suitably qualified operators should be aware of the regulations and standards set down by the industry/country for the testing or calibration of this unit. This manual is only intended as a guide and, insofar as permitted by law, the manufacturer accepts no responsibility for the calibration, testing, or operation of this unit.

The frequency and nature of testing or calibration may be determined by local regulation or standards.

EN378 and the F-GAS Regulation require an annual check in accordance with the manufacturer's recommendation.



IMPORTANT: In applications where life safety is critical, calibration should be done quarterly (every 3 months) or on a more frequent basis. Murco is not responsible for setting safety practices and policies. Safe work procedures including calibration policies are best determined by company policy, industry standards, and local codes.



NOTE: For improved accuracy and response, the instrument should be zeroed and calibrated in the environment in which it is being installed.

There are two concepts that need to be differentiated:

Bump Test Exposing the sensor to a gas and observing its response to the gas. The objective is to establish if the sensor is reacting to the gas and all the sensor outputs are working correctly. There are two types of bump test.

- **Quantified:** A known concentration of gas is used.
- **Non-Quantified:** A gas of unknown concentration is used.

Calibration Exposing the sensor to a calibration gas, setting the “zero” or “Standby voltage”, the span/range, and checking/ adjusting all the outputs, to ensure that they are activated at the specified gas concentration.

CAUTION: Before you carry out the bump test or calibration:



- Advise occupants, plant operators, and supervisors.
 - Check if the MGD is connected to external systems such as sprinkler systems, plant shut down, external sirens and beacons, ventilation, etc. and disconnect as instructed by the customer.
 - For one-alarm systems you should deactivate the 3-min alarm delay (if selected) by moving jumper JP1 to the “off” position.
 - Ideally, for bump test or calibration the MGD should be powered up overnight. See Section 5 for more information.
-

6.2. Electrical Reset of One-Alarm Systems

Reset, if necessary, the Standby and Alarm Threshold Voltage to the factory settings as shown on the calibration label. Electrical reset information is listed on the label on the side of the enclosure and is unique to that sensor. Two adjustments are required and they are performed on the MGD controller unit.



NOTE: If the sensor standby voltage (SSV) is greater than the alarm threshold voltage, as in when a gas leak occurs, then an alarm condition occurs (red LED, siren, relay operates).

If the SSV falls below 0.18 V, a fault condition will be shown on the controller (red LED, no siren, relay does not operate).

Tools required:

- A voltmeter (crocodile clips recommended)
- Factory set point electric values (as shown on the rating label)
- Screwdriver (depending on enclosure).

Step	Electrical Reset of One-Alarm Systems
1	First disable the 3-minute alarm delay by moving the jumper link at JP1 to the “OFF” position. See Figure 13 and Figure 15.

Step	Electrical Reset of One-Alarm Systems
2	Connect a voltmeter between Pins 4 (-Ve) and 2 (+Ve) of the sensor terminal connector block for each channel in turn (CN1, CN2, etc.) and adjust the corresponding calibration pot (P1, P2, etc.) to the sensor standby voltage (SSV) value as per calibration label on side of enclosure. (For IR sensors, set SSV to 2V.) See Figure 13 and Figure 15.
3	The alarm threshold voltage (ATV) is the voltage at which the alarm and relay activate at a given gas concentration. This voltage is normally set to 3.0V at the factory and is adjusted using: <ul data-bbox="216 501 822 564" style="list-style-type: none">• pot “P3” for 1- or 2-channel units (see Figure 1)• pot “P7” for 4- or 6-channel units (see Figure 2) Measure between pins 4 (-Ve) and 1 (+Ve) on the Cal header. See Figure 13 and Figure 15.
4	For the alarm set point, connect the DC voltmeter between 0V (TP5) and High (TP1) (see Figure 5 on page 9). Adjust P7 to the alarm set point as per the rating label (normally 1.2V).
5	Carry out a bump test to ensure the sensor is functioning correctly. See section 6.4 on page 37.
6	If the sensor does not go into alarm, carry out a gas calibration. See section 6.8 on page 41 and section 6.9 on page 43.
7	Finally, return jumper JP1 of the controller to its original position.

6.3. Electrical Reset of Two-Alarm Systems

If necessary, reset the Standby and low/high Alarm Threshold Voltages to the factory settings as shown on the calibration label. This is performed on the MGD Sensor PCB.

Electrical reset information is listed on the label on the side of the enclosure and is unique to that sensor.

Tools required:

- A voltmeter (crocodile clips recommended)
- Factory set point electric values (as shown on the rating label)
- Screwdriver (depending on enclosure).

Step	Electrical Reset of Two-Alarm Systems
1	For the sensor standby voltage, connect a DC voltmeter between TP5 (0V) and TP4 (+V) as shown in Figure 14 and Figure 16. Adjust pot RV1.
2	For low-level alarm voltage, connect your DC voltmeter between TP5 (0V) and TP2 (+V) as shown in Figure 14 and Figure 16. Adjust pot P8.
3	For high-level alarm voltage, connect your DC voltmeter between TP5 (0V) and TP1 (+V) as shown in Figure 14 and Figure 16. Adjust pot P7.

6.4. Bump Testing

After installation the units should be bump tested. Expose the sensors to test gas ampoules (NH₃, CO₂, etc.) or test cylinder gas (appropriate to the installation). The gas is heavier than air and should fall into the sensor, putting the system into alarm and lighting the red LED. If a delay is set, the delay will prevent the audible alarm from sounding or the relay from switching.

Use a bump test to see the functions of the sensor - the yellow/red LED will light, and the relay and audible alarm will function.

Ideally bump tests are conducted on site in a clean air atmosphere.



NOTE: Prior to carrying out a bump test, check and adjust the zero setting as described in the Calibration section.



NOTE: Procedures for bump test and calibration vary depending on the sensor technology used and the gas in question. The MGD is available in two sensor versions: Semiconductor (SC) and Infrared (IR).



NOTE: Do not pressurise the sensor.



NOTE: For semiconductor sensors, you **MUST** use calibration gas in a balance of air (*not* N₂).

Step	Bump Testing Using Calibration Gas Cylinders
1	Remove the enclosure lid of the gas sensor and controller (not applicable to Exd Remote sensor and vent pipe model as monitoring of voltage can be done on controller).
2	Connect the voltmeter to the channel under test between Pin 4 and Pin 2 (for single-level alarm units), or TP5 and TP4 (for dual-alarm units), to monitor sensor response.
3	Expose the sensor to gas from the cylinder by using a plastic hose/hood to direct gas to the sensor head.

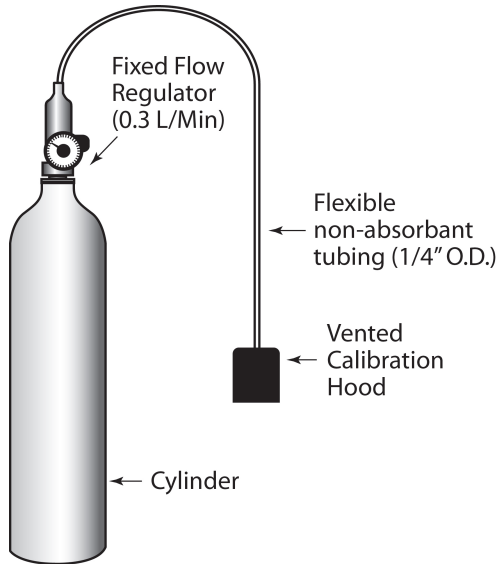

Figure 17. Gas Cylinder and Test Hardware



NOTE: If the bump test is unsuccessful, perform a calibration as described later in this manual.



IMPORTANT: After a semiconductor sensor is exposed to a substantial gas leak, the sensor should be checked and replaced if necessary.

Gas ampoules are convenient and inexpensive alternatives to using gas cylinders for bump testing.



Figure 18. Gas Ampoules for Bump Testing

Step	Bump Testing Using Gas Ampoules
1	Make sure that both the ampoules and the calibration beaker are clean and dry.
2	Unscrew the beaker wing nut and place the ampoule so that it sits in the base of the beaker (see Figure 18).
3	Tighten the wing-nut screw onto the ampoule without breaking it.
4	Remove the enclosure lid of the gas detector.
5	Connect the voltmeter to the channel under test between Pin 4 and Pin 2 (for single-level alarm units), or TP5 and TP4 (for dual-alarm units), to monitor sensor response.
6	Place the beaker over the sensor head using the multi sensor adaptor to fit the sensor, or, if an Exd, IP66 or remote sensor head version, screw the beaker on the remote sensor head M42 thread or M35 thread adaptor. It should be as tight fitting as possible to allow maximum gas exposure.
7	Tighten the wing nut screw onto the ampoule until it shatters, allowing the gas to diffuse in the beaker. It should be left in place for approximately 5 minutes.

Step	Bump Testing Using Gas Ampoules
8	The voltage output will increase. This confirms that the sensor is responding. A response equivalent to at least 50% (typically) of the test gas will confirm that the system is in order.
9	Remove the beaker from the sensor. Carefully remove any ampoule remains from the gas detector and beaker.

6.5. Calibration Overview

To comply with the requirements of EN378 and the European F-GAS regulation, sensors must be tested annually. However, local regulations may specify the nature and frequency of this test.



CAUTION: Check local regulations on calibration or testing requirements.

6.6. Calibration Options

There are two available calibration options:

- Exchange the remote sensor for a new, pre-calibrated one and send old one to Murco for recalibration (available for two-alarm units and 1- and two-alarm IR units)
- On-site gas calibration.

6.7. Sensor Board Exchange

There are a number of advantages to sensor board exchange. It is simpler and quicker than gas calibration.



NOTE: Sensor board exchange is available for two-alarm semiconductor (SC) units and single alarm and dual alarm infrared (IR) units.



NOTE: Murco recommends exchanging your sensor PCB for a new pre-calibrated one every 3 years.

Tools required:

- A pre-calibrated sensor board
- A voltmeter (crocodile clips recommended)

Step	Sensor Board Exchange
1	Power off the unit and remove lid of sensor enclosure.
2	Note the color code of the cable in positions 1,2,3 and 4 of the connector block.
3	Undo the cable and 2 screws securing the sensor board and remove the board.
4	Fit the new pre-calibrated sensor and reconnect the cable in the correct colour sequence at positions 1,2,3 and 4.
5	Power on the unit and allow to stabilise for 15 minutes (minimum).
6	Check voltage readings on positions 1,2,3 and 4 (see Table 1 on page 45) to ensure that wiring is correct. Note also in the table how to monitor the sensor as it stabilises.
7	Perform a bump test to confirm the sensor is responding.
8	Keep records of the test date, sensor serial number, and any observations.

6.8. On-Site Gas Calibration (One-Alarm Unit)

This section and the next cover calibration using calibration gas cylinders. Murco offers a calibration kit that consists of a calibration gas cylinder and a flow regulation valve with flexible non-absorbent tubing and vented calibration hood.

In some cases this option may be expensive relative to sensor exchange because of the cost of visiting a site, calibration gas, etc.

The procedure involves electrical set-up followed by adjustment using calibration gases. Equipment required is as follows:

- Gas cylinder with the appropriate target gas and concentration
- Fixed flow regulator – rate 0.3L/min
- A voltmeter.



NOTE: This calibration procedure is for a 1-alarm unit. For 2-alarm units, refer to the calibration procedure in the next section.

First disable the 3-minute alarm delay on a one-alarm system by moving the jumper link at JP1 to the off position. Two adjustments are required and they are both performed on the controller unit.

The alarm threshold voltage (ATV) is the voltage at which the alarm and relay activate at a given gas concentration. This voltage is normally set 3.0V.

Step	Adjusting the Alarm Threshold Voltage (ATV)
1	This voltage (measured on the CAL header) is set using: <ul style="list-style-type: none">• 1 or 2 channel system controllers - the threshold pot "P3"• 4 or 6 channel system controllers - the threshold pot "P7"

If the sensor standby voltage (SSV) is greater than the alarm threshold voltage, as in when a gas leak occurs, then an alarm condition occurs (red LED, siren, relay operates).

If the SSV falls below 0.18 V, a fault condition will be shown on the controller (red LED, no siren, relay does not operate).

Step	Adjusting the Sensor Standby Voltage (SSV)
2	Connect a voltmeter between Pins 4 (-Ve) & 2 (+Ve) of the sensor terminal connector block for each channel in turn (CN1, CN2, etc.).
3	Apply calibration gas of the desired concentration to the sensor and wait until the sensor output signal stabilises, then adjust the pot that corresponds to the channel being calibrated. This should be adjusted until the sensor goes into alarm and the red LED turns on. (Setup alarm voltage to 0.05V above the alarm setting.)
4	Remove the calibration gas and allow the sensor to return to its standby voltage.
5	Record this voltage reading and keep on record for subsequent electrical set-ups. This is now calibrated for the gas concentration used. Repeat for any subsequent channels.
6	Finally, return jumper JP1 to its pre-calibrated position.

6.9. Gas Calibration (Two-Alarm Units)



NOTE: This calibration procedure is for a two-alarm unit. For one-alarm units, refer to the calibration procedure in the previous section.



NOTE: The delay on a two-alarm system is approximately 25 seconds and cannot be deactivated.

All adjustments are performed on the MGD sensor PCB. The Sensor Standby Voltage and two Alarm Threshold Voltages must be adjusted.

Step	Adjusting the Sensor Standby Voltage (SSV)
1	Connect the voltmeter between TP5 (0V) & TP4 (+Ve) and adjust pot RV1 for 0.3V (on IR units SSV is fixed).

Step	Adjusting the Low Alarm Threshold Voltage (ATV)
2	Monitor the voltage between TP5 (0V) & TP4 (+Ve)/0V and VS on IR units.
3	Apply the low concentration calibration gas to the sensor and wait until the sensor output signal stabilises. Record this voltage.
4	Adjust P8 to the new value. Record and use the new value for subsequent electrical set-ups.

Step	Adjusting the High Alarm Threshold Voltage (ATV)
5	Monitor voltage between TP5 (0V) & TP4 (+Ve)/0V and VS on IR units.
6	Apply the high concentration calibration gas to the sensor and wait until the sensor output signal stabilises. Record this voltage.
7	Adjust P7 to the new value. Record and use the new value for subsequent electrical set-ups.



CAUTION: The high alarm threshold voltage must be set higher than the low alarm threshold or the unit will not function correctly.

Section 7. Troubleshooting

Symptom	Possible Cause(s)
No lights displayed on panel	<ul style="list-style-type: none">• Power failure (check supply)• Tripped circuit breaker or blown fuse on electrical supply• Blown fuse at the electrical supply on the controller PCB board
Red light is on, but no alarm condition is active (i.e., no siren and no relay operation after 3 minutes)	<ul style="list-style-type: none">• Make sure the siren has not been deactivated (key switch on two-alarm, controllers, link on jumper JP1 on one-alarm controllers removed).• This indicates a wiring or sensor fault (call service provider). If these are in order the calibration pot may have been adjusted and may need to be reset. Check with the factory for instructions.
Controller is on, but the MGD is not	<ul style="list-style-type: none">• This may indicate a wiring fault between the controller and sensor or a sensor fault. Check power supply to the controller. Check connections between the controller and the sensor to ensure that the wires from positions 1 to 4 on the sensor are connected to the corresponding 1 to 4 connectors on the controller.• On a 4 to 6 channel unit, check that the sensor fuse is not blown on the corresponding sensor connection position in the controller.

NOTE: If false alarms are being triggered by background gases, paint fumes, etc., or extreme humidity or temperature conditions, you may adjust the settings to compensate.



One-Alarm Systems: You should reduce the SSV level in 0.5V increments until the condition clears.

Two-Alarm Systems: You should adjust the relevant alarm threshold voltage upwards in 0.2 V increments until the condition clears.

To make sure the gas detectors are wired correctly, you can check the voltages at the sensor cable terminal blocks on the controller PCB or sensor PCB using a voltmeter as outlined below in Table 1.

Place the negative probe on terminal position 4 and with the positive on 1, 3, 2, check the values. The readings are lower at the sensor due to power drop in the line.

The terminals should have the values shown in the table below.

You can monitor this as follows:

- **One-Alarm Systems:** Connect a voltmeter and monitor voltage between Pins 4 (-Ve) and 2 (+Ve) of the sensor terminal connector block for each channel in turn (CN1, CN2, etc.) For IR monitor between 0V and VS.
- **Two-Alarm Systems:** Connect voltmeter and monitor voltage between TP5 (0V) and TP4 (+Ve). For IR monitor between 0V and VS.

Table 1. Connections Correct Values

Position Number	At the Sensor	Controller	Without Sensor Fitted
1	Power supply 7.2V minimum reading, unless you have power drop reduction.	+10V	+12-15V
2	<u>one-alarm system</u> - Sensor standby voltage* as shown on the calibration label on the side of the enclosure. <u>two-alarm system</u> - Typical internal reference values, approximately	(0=Fault)	0
		+0.4V	Sensor in standby
		+1.6V	Low Alarm Condition
		+2.8V	High Alarm Condition
3	Approximately 4-5V	+4.8-5V	+5V
4	Is the negative side of the power supply	Negative	Negative

* The voltage signal from the sensor will start high and gradually fall (in clean air) to the SSV value shown on the calibration label. IR unit will display 0Volts until the 2 minute warm-up has finished.



CE DECLARATION OF CONFORMITY

The manufacturer of the products covered by this declaration:	Murco Ltd 114a George's Street Lower Dun Laoghaire Ireland
Year(s) conformity is declared:	2012 (IEC/EN61010), 2011 (EN61326)
Product(s):	MGD
Model(s):	MGD

The undersigned hereby declares that the above referenced products are in conformity with the provisions of the following standards and is in accordance with the following directive.

Directive(s):

2004/108/EC	EU EMC Directive
2006/95/EC	Low Voltage Directive (LVD)

Standard(s):

IEC 61010-1: 2010 EN 61010-1: 2010	Safety Standards	Electrical Equipment for Measurement, Control, and Laboratory Use; Part 1: General Requirements
EN 61326-1: 2006	Electromagnetic Compatibility (EMC) Standards	Electrical equipment for measurement, control and laboratory use - EMC requirements - Part 1: General requirements

Signature:  _____

Name: Philip Hassell
Title: Engineering Manager
Date: 12th March 2013

The technical documentation file required by this directive is maintained at the corporate headquarters of Murco Ltd.



MURCO
114A GEORGE'S STREET LOWER
DUN LAOGHAIRE • CO DUBLIN • IRELAND

Phone: +353 1 284 6388 • Fax: +353 1 284 6389
www.murcogasdetection.com • sales@murco.ie