



5-in-1 gas detector with built-in pump



Technical parameters

Sampling by: Pump
Alarms: voice, visual, vibration
Operating temperature: -20°C - +50°C
Battery: Li-Ion 3.7V cells
Charging time: 4-6 h
Display: 2.4" color LCD
Operating time: minimum 10h
ATEX: (Ex) II3G Ex ic IIC T4 Gc

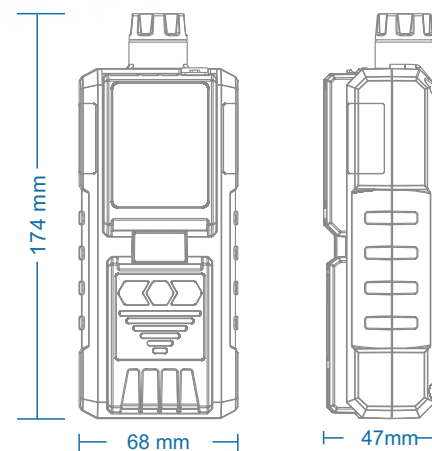

Wymiary: 174x68x47mm

JB-M6K 5-in-1 gas detector with integrated pump

The K-600 5-in-1 portable gas detector with built-in pump is a new intelligent detector that uses an advanced integrated circuit with standard intelligent level design technology and proprietary digital-analog-hybrid communication technology. The detector has excellent sensitivity and repeatability, making it very easy to operate and maintain. It perfectly meets the requirements of industrial plants for high reliability security. The detector is made of high-strength constrictive materials, a non-slip rubber compound that provides high strength and good feel in the hand. The sensor is waterproof, dustproof and explosion-proof. It is widely used in petroleum, chemical, environmental protection, metallurgy, refining, gas transmission and distribution, biochemical medicine, agriculture and other industries.

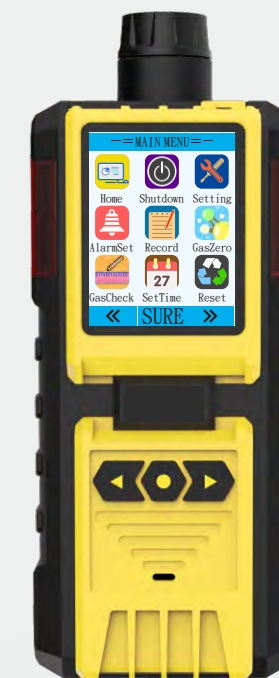

- Industrial sensor
- Three methods of alerting
- High-capacity battery
- Multilingual menus
- Clear interface
- Explosion-proof, waterproof, dustproof

Dane techniczne

Gas	Range	Units	Measurement deviation
EX	0.00-4.00	%	0.01%
H2S	0-100	10 ⁻⁶	1 × 10 ⁻⁶
CO	0-1000	10 ⁻⁶	1 × 10 ⁻⁶
O2	0.0-30.0	%	0.1%
CO2	0.00-5.00	%VOL	0.01%VOL



(+48) 17 745 65 30 biuro@jbk.com.pl
 JBK FHU Bogusław Kliś
 39-120 Sędziszów Młp.
 ul. Piaskowa 52
 NIP 8191226557